

- Black heatshrink fibreglass, chrome mount ferrule
- Mounts to any antenna base with 5/16"-26 TPI male thread

AM/FM Radio  
Receive Whip,  
1.83 metre

Model  
**CR66-HD-TPM**

Model



## DESCRIPTION

To boost AM and FM radio reception, the CR66-HD-TPM heavy duty whip offers the very best reception range practical in a mobile car radio antenna.

Standing 1.83 metres tall, the whip is fully braided with fibreglass core, black UV stabilised heatshrink cover and chrome plated brass ferrule.

This lightweight antenna can be fitted to any antenna base with a 5/16"-26 TPI thread and mounted in various locations, either fixed or mobile.

The ZCG Scalar antenna bases listed below are recommended.

## TUNING

The antenna tune has been optimised in the factory to receive AM Radio, 530 to 1600 KHz and FM Radio, 88 to 108 MHz.

This tuning cannot be altered.

## SELECTING THE MOUNTING POSITION

The typical mounting positions for this antenna include a vehicle bull bar, vehicle guard, the boot of a sedan or a truck mirror using the appropriate base and bracket.

The antenna can also be mounted in locations other than on a vehicle.

To achieve best performance from your antenna, these are the important principles you should consider when selecting the mounting point:

1. **Mount the antenna in as high a place as possible.**
2. **Mount the antenna as far away from other antennas and metallic objects as possible to avoid interference and distortion of the 360° omnidirectional pattern. At least 350 mm side clearance is desirable, preferably more.**
3. **Mount the antenna vertical, not at an angle.**

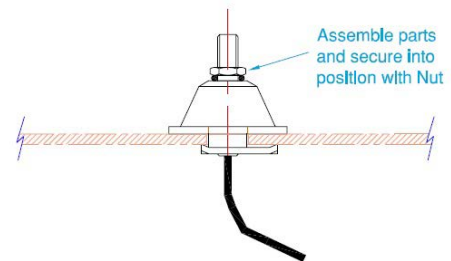
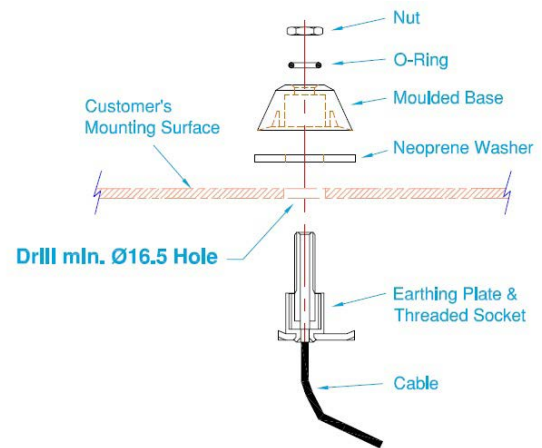

## Mounting bases recommended and available separately

### OB-2

Australian Standard UHF OB Base, Black, 5/16"-26 TPI thread, no cable, no connector

### CRBL

OB-2 Base, Black, 5/16"-26 TPI thread, 4 metres of RG58 low loss stranded cable with car radio connector fitted

### MGB-OB

Magnetic OB-2 Base, steel with polished black powder coat finish, 10.5 cm diameter, heavy duty magnet, PVC matted pad on bottom, 4.7 metres RG58 low loss stranded cable side exits, no connector

**We also stock a complete range of vehicle mounting brackets. Visit [www.zcg.com.au](http://www.zcg.com.au) for details.**