

Assembly Sketch

UAM180UNIL-48 CLAMP KIT

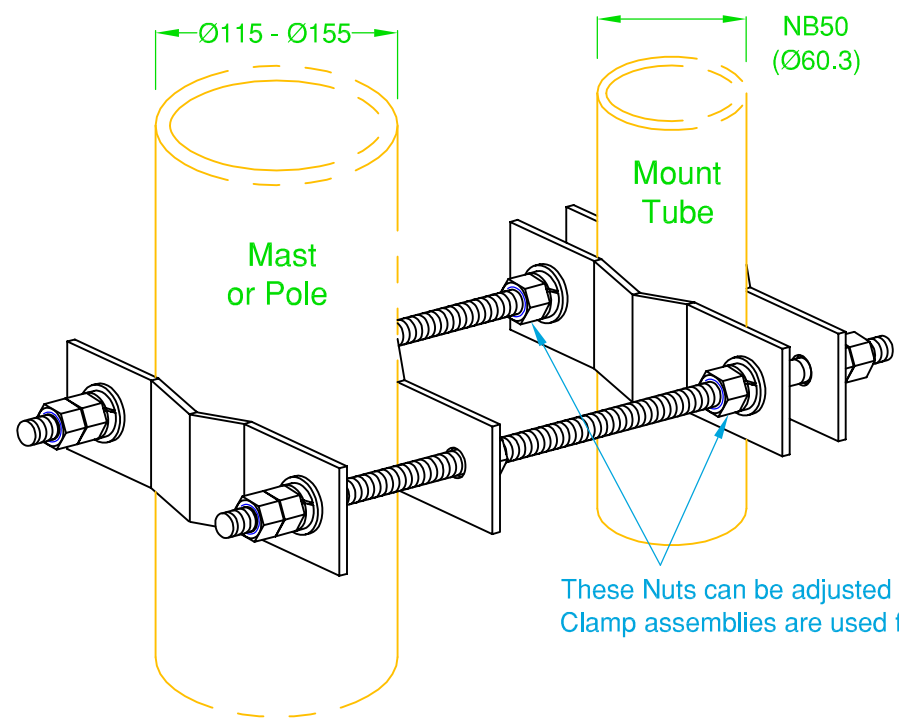

ASSEMBLY:

- Fit an inner 2 sets of Nuts, Spring Washers & Flat Washers to each Allthread
- Place a Clamp Bar up to each set of Nuts and Washers
- Place around Mast/Pole & fit Clamp Bar, Washers & Nuts then tighten. Fit Locking Nuts - tighten
- Install Mount Tube following same steps in c.
- Install all Locking Nuts - tighten

These Nuts can be adjusted for tilt angle when two Clamp assemblies are used for the Mount Tube

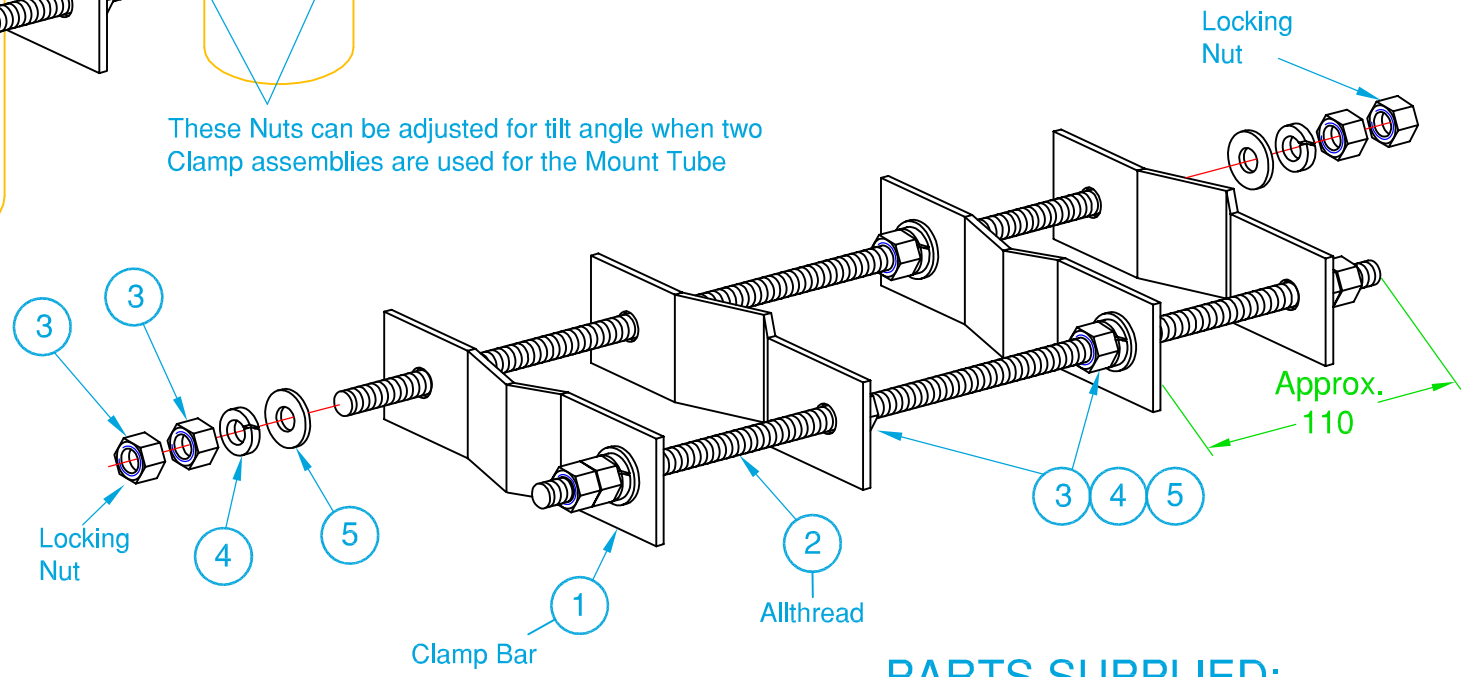

PARTS SUPPLIED:

6		
5	Washer, Flat, Galvanised, Ø1/2"	8
4	Washer, Spring, Galvanised, Ø1/2"	8
3	Nut, Hex, Galvanised, M12	12
2	Allthread, MS, Galvanised, M12 x 480mm	2
1	Clamp Bar, MS, Coated	4
Item	Description	Quantity.

G-Tech Communication Services Pty. Ltd. Trading as:
ZCG SCALAR®
 DESIGNERS AND MANUFACTURERS OF RADIO FREQUENCY ANTENNAS
 Hall Street, Lindenow, Victoria, Australia.
 Tel: (03) 5157 1203 Fax: (03) 5157 1641

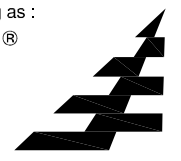

Copyright - **G-Tech** Communication Services Pty. Ltd. No part of this Drawing is to be reproduced without Written Authority

1205-5-B.dwg LM 03-10-13
 Approved: GK 03-10-13